

## API 685 Canned Motor Pumps



## Specifying and installing an API 685 pump is not just a matter of compliance. It's about working together to meet plant requirements for safety and risk management to assure project success.

With Teikoku sealless canned motor pump solutions, you can decide the exact level of API 685 compliance needed to configure a pump to individual user/plant specifications. You choose the options based on project cost, fluid, QA and safety parameters. Only Teikoku's unique menu-driven manufacturing approach gives you this flexibility. What else would you expect from the global leader in canned motor pump technology?

When it comes to configuring and operating an API 685 pump, we realize there is no such thing as "one size fits all." With the numerous fluid circulation plans, containment systems, support and instrumentation options available under API 685, you need assurance for supply of required features. However, you shouldn't have to pay for more pump than your application requires. That's why the experts at Teikoku developed the only menu-based system for ordering, configuring and documenting API 685 pumps that considers individual user requirements in all designs.

This brochure highlights a high-temperature application. Start with our standard Plan 23-S pump and build on further API 685 compliance. Add accessories and upgrades to



*API 685 Plan 23-S Sealless Canned Motor Pump designed and manufactured to exact user requirements for API 685 compliance, instrument selection, enclosure area classification and documented Quality Assurance*

achieve the precise levels of plant compliance, safety and emission control needed to meet end-user or engineering firm standards. All Teikoku pumps are engineered for peak performance – with pumps and hermetically sealed motors designed to work in concert for maximum efficiency and long-term operating reliability. And it's all backed by the design, manufacturing, field support and start-up resources of the global Teikoku Group.

### Teikoku API 685 Benefits:

- Secondary containment is standard issue
- Instrumentation to meet user-/client-established standards and local compliance for safety and reliability monitoring
- Rotating assembly position monitors for real-time bearing wear indication and preventative maintenance scheduling
- Third-party labeled explosion-proof designs to global standards
- Operator and maintenance personnel training and start-up assistance offered at no cost to users

## Standard High-Temperature Service Canned Motor Pump

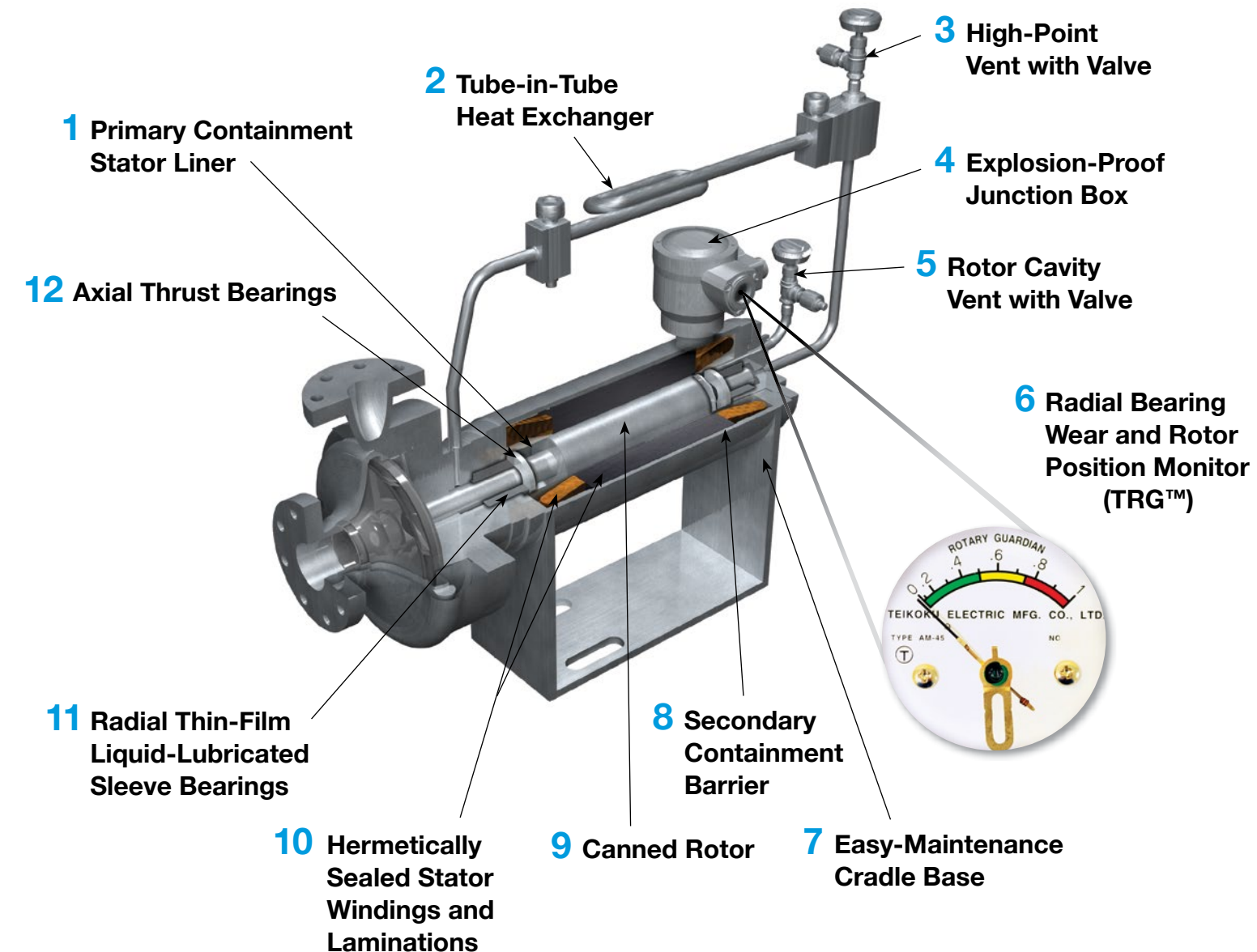

<b>13</b>	Design Pressure Rated Shell and Tube Heat Exchanger	6.1.20
<b>14</b>	Design Pressure Rated Utility Piping and Connections	6.1.24
<b>15</b>	Design Pressure Rated Terminal Plate Seal and Junction Box	7.4.2.4
<b>16</b>	Design Pressure Rated Process Piping and Connections	6.3.1.1
<b>17</b>	Design Pressure Rated Rotor Cavity Drain with Gussets (Gussets omitted for clarity)	6.1.11
<b>18</b>	Design Pressure Rated Stator Cavity Flush and Drain Connections	6.7.9
<b>19</b>	Design Pressure Rated Secondary Containment	6.7.5
<b>20</b>	Stud Bolts	6.1.34
<b>21</b>	Design Pressure Rated Pump Casing Drain with Gussets (Gussets omitted for clarity)	6.3.3.5
<b>22</b>	Replaceable Impeller Wear Rings	6.6
<b>23</b>	Design Pressure Rated Pump Casing and Adapter	6.2.1

## Mechanical Design

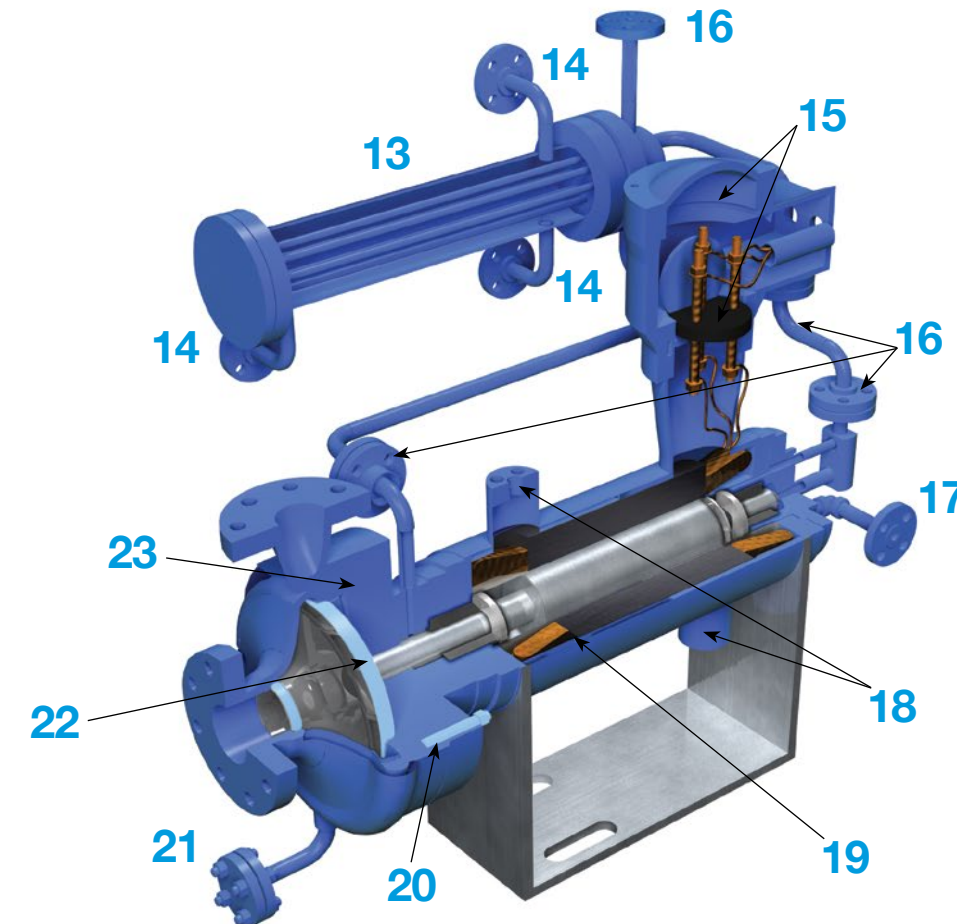



<b>24</b>	Heat Exchanger Supports	7.3
<b>25</b>	Lifting Brackets	7.3
<b>26</b>	Extended Baseplate with Drain Pan (Optional for Canned Motor Pumps) If specified, design details available.	7.3 9.1.5.3
<b>27</b>	Cradle Gussets	7.3
<b>28</b>	Pump Casing Centerline Supports	6.2.9

## Unit Support

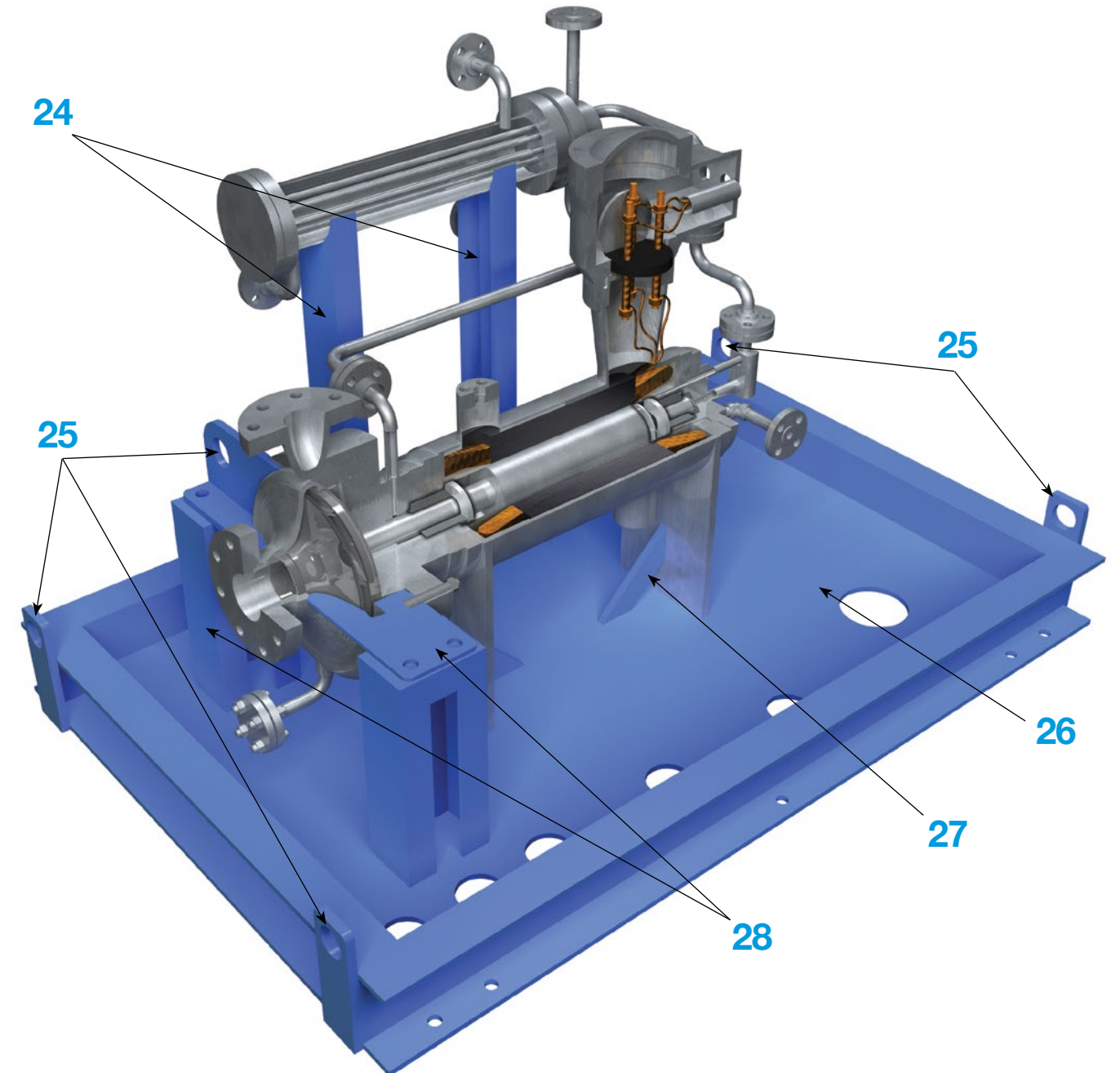

<b>29</b>	Heat Exchanger Access Connection	6.3.3
<b>30</b>	Rotor Cavity Access Connection	6.3.3
<b>31</b>	Instrument Junction Box Support – First Edition	7.2.1.4
<b>32</b>	Transmitter Support Bracket	6.3.3
<b>33</b>	Secondary Containment Access Connection	6.3.3

## Electrical and Instrument Connection

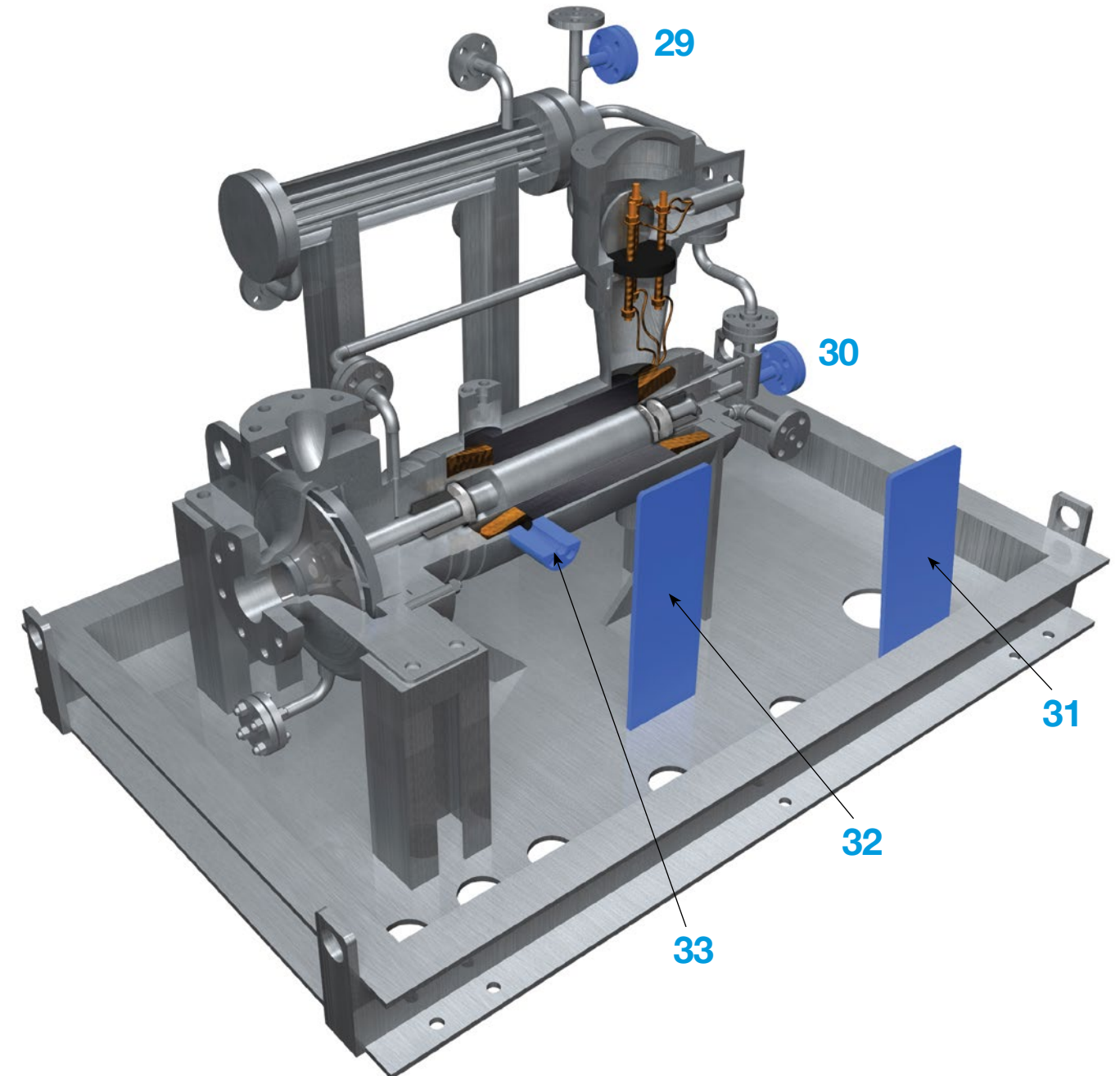

<b>34</b> Heat Exchanger Level Sensor	Annex E.LE1
<b>35</b> Radial and Axial Rotor Position Monitor (THG™)	7.4.1.3
<b>36</b> Vibration Pads	Annex E.VE
<b>37</b> Stator Winding RTD	Annex E.TE1
<b>38</b> Stator Liner Temperature Sensor	7.4.2.1
<b>39</b> Rotor Cavity Temperature Probe	Annex E.TE2
<b>40</b> Instrument Junction Box – First Edition	7.2.1.4
<b>41</b> Secondary Containment Pressure Transmitter	7.4.2.3
<b>42</b> Power Monitor	7.4.2.1
<b>43</b> Secondary Containment Pressure Sensor (TPS)	7.4.2.3

## Electrical and Instrument

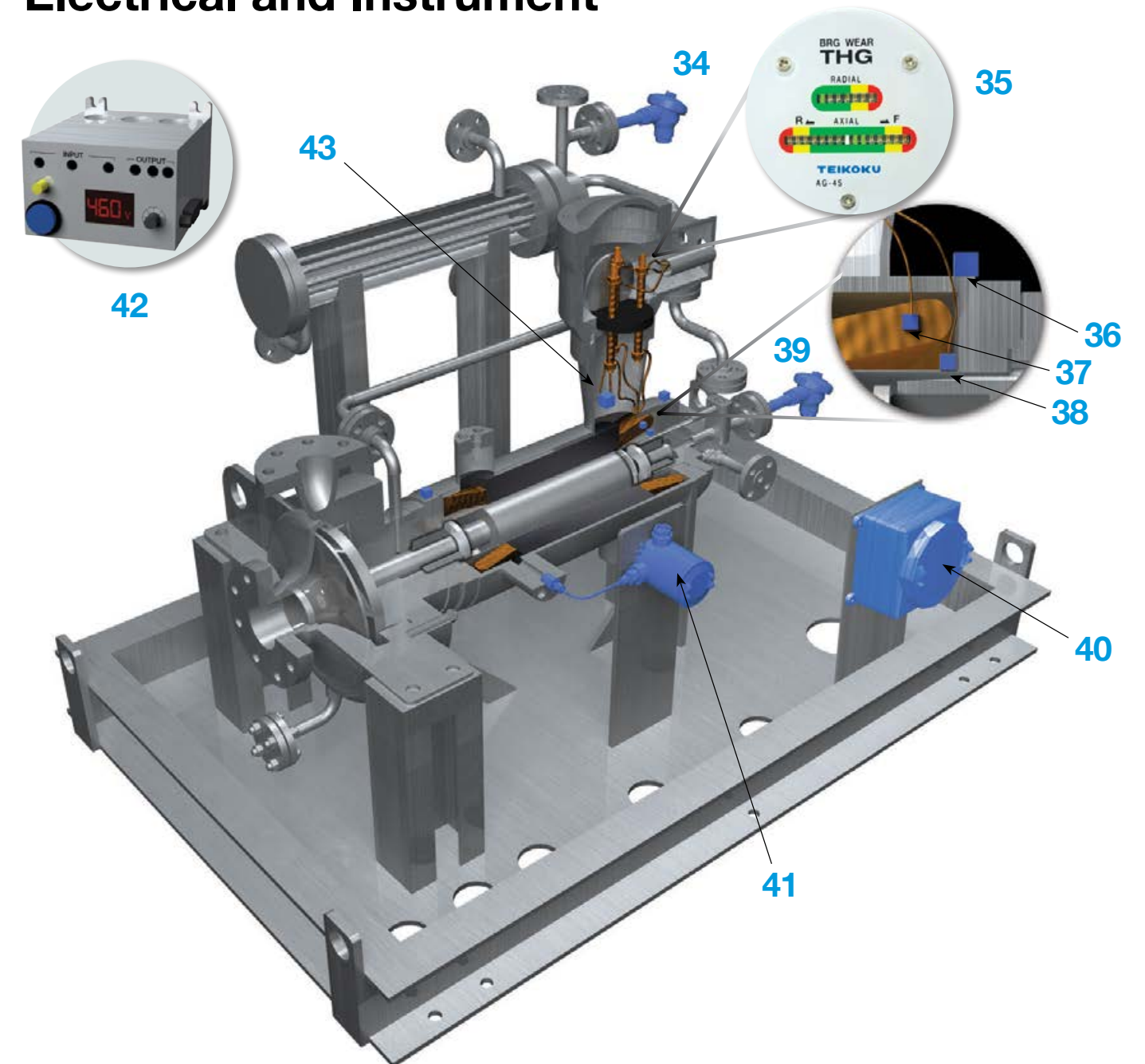



# Annex D Dirty or Special Circulation Fluid Plans

# Annex D Clean Circulating Fluid Plans

All sealless Teikoku Canned Motor Pumps can be designed and manufactured for use as envisioned under API 685 Annex D, Circulation Piping Schematics. These canned motor pump circulation plans offer users a view into handling a variety of clean and dirty fluid pumping applications in the emission-free, safe

and highly reliable way that can only be achieved with canned motor pumps. The API 685 Circulation Plan possibilities are characterized here in generic cross sections of applied canned motor pump technology designed for applications to accommodate volatile, solids-laden, hot and temperature-sensitive fluids.

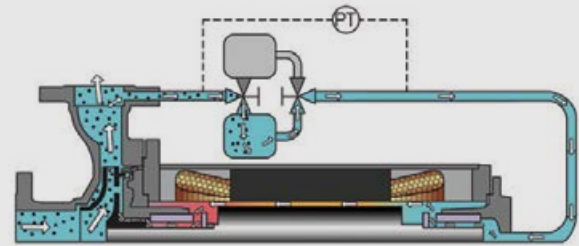

Plan 12-SE Filtered External Circulation



Plan 32-S External Fluid Flush Circulation

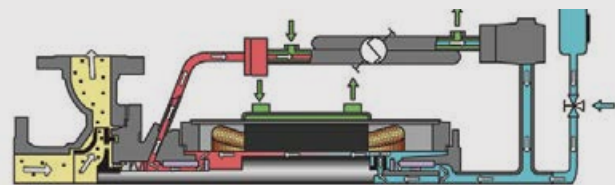

Plans 53-S & 54-S Pressurized or External Make-Up and Cooled Flush for Isolated Motor

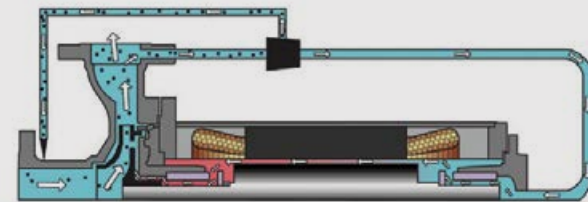

Plan 31-S External Circulation with Separator

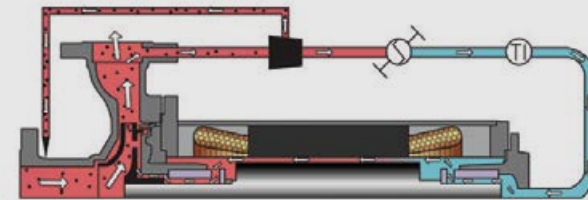

Plan 41-S Cooled External Circulation with Separator

For even more varieties of Teikoku solutions under API 685 Plans, visit our Pump Circulation Paths at [www.TeikokuPumps.com](http://www.TeikokuPumps.com).

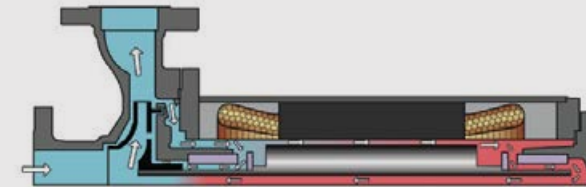

Plan 1-S Internal Circulation

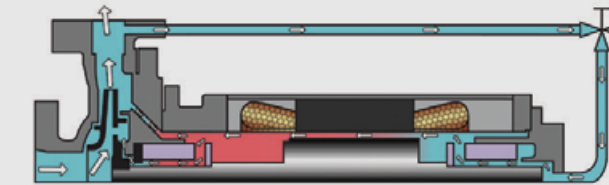

Plan 2-S External Circulation for Start-Up Flush

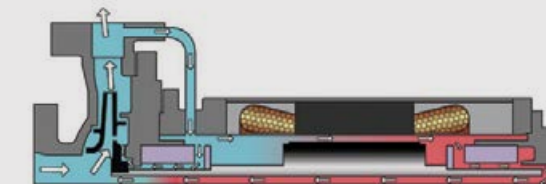

Plan 13-S Inboard Return External Circulation

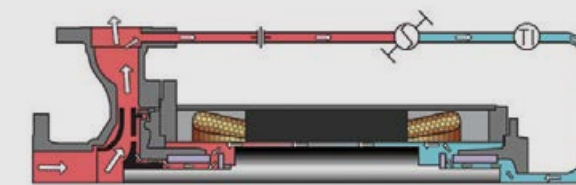

Plan 21-S Cooled External Circulation

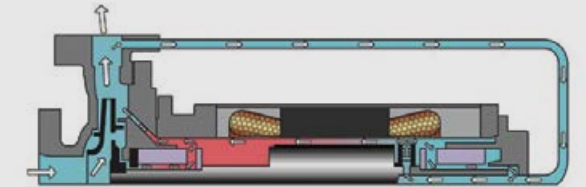

Plan 1-SD Pressurized Circulation

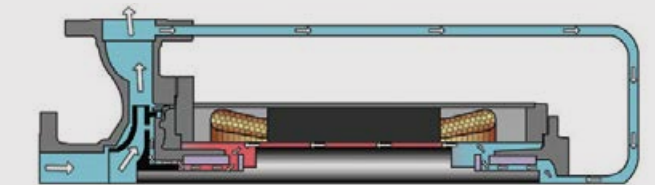

Plan 11-S Outboard Return External Circulation



Plan 13-SE Reverse Circulation

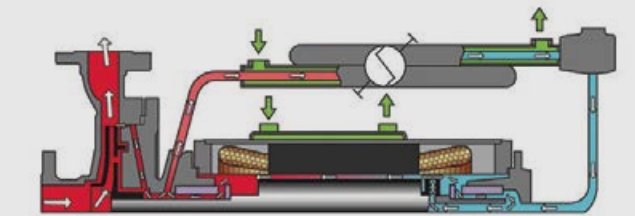

Plan 23-S Auxiliary Impeller Circulated and Cooled Isolated Motor

# Teikoku Group Global Network

## Teikoku Electric Mfg. Co., Ltd. (Japan)

### Plant & Business Headquarters

Postcode 679-4395  
60 Hirano, Shingu-Cho, Tatsuno-Shi, Hyogo-Ken, Japan  
Phone: +81-791-75-0411  
[www.TeikokuDenki.co.jp](http://www.TeikokuDenki.co.jp)

### International Business Headquarters

Postcode 110-0015  
6F Shitaya Bldg.  
2-5, 5-chome, Higashi-Ueno, Taito-Ku, Tokyo, Japan  
Phone: +81-3-3841-9311

## Teikoku USA Inc (North & South America)

959 Mearns Road  
Warminster, PA 18974 USA  
Phone: +1-215-343-6000  
[www.TeikokuPumps.com](http://www.TeikokuPumps.com)

## Teikoku USA Inc (US Gulf Coast Sales and Service Center)

5880 Bingle Road  
Houston, TX 77092 USA  
Phone: +1-713-983-9901  
[www.TeikokuPumps.com](http://www.TeikokuPumps.com)

## Dalian Teikoku Canned Motor Pump Co., Ltd. (China)

Sanjianpu Science & Technology Industry Area  
Dalian, China  
Phone: +86-411-8626-9657  
[www.Teikoku-China.com](http://www.Teikoku-China.com)

## Taiwan Teikoku Pump Co., Ltd.

9F-1, No. 5, Jinzhou St., Zhongshan District  
Taipei City 104, Taiwan, ROC  
Phone: +886-2-2567-9800

## Other International Subsidiaries

### Teikoku Electric GmbH (Europe)

Nürnberg Strasse 24, D-40599  
Düsseldorf, Germany  
Phone: +49-211-700-6778  
[www.TeikokuPump.de](http://www.TeikokuPump.de)

### Teikoku South Asia PTE, Ltd. (Southeast Asia)

No. 15 Joo Koon Crescent  
Singapore 629015  
Phone: +65-6861-4121  
[www.TeikokuPumps.com](http://www.TeikokuPumps.com)

### Teikoku Korea Co., Ltd. (Korea)

3F Woonam Bldg., 35, Gangnam-daero, 112 Gil  
Gangnam-gu, Seoul, 135-827, Korea  
Phone: +82-2-790-7012  
[www.TeikokuKorea.co.kr](http://www.TeikokuKorea.co.kr)

### Teikoku Electric Mfg. Co., Ltd. (Middle East – India)

Regional Office  
Al Moayyed Tower, 22nd Floor, Room 2225  
Bldg. 2504 Road 2832, Blk 428  
Al Seef District, PO Box 18259  
Manama, Kingdom of Bahrain  
Phone: +973-17-568-191

Visit us online at  
[www.TeikokuPumps.com](http://www.TeikokuPumps.com).

